

LIVING AREA: 2698.58 sq ft • FLOORS: 3

▼ Ground Floor

LIVING AREA: 951.15 sq ft

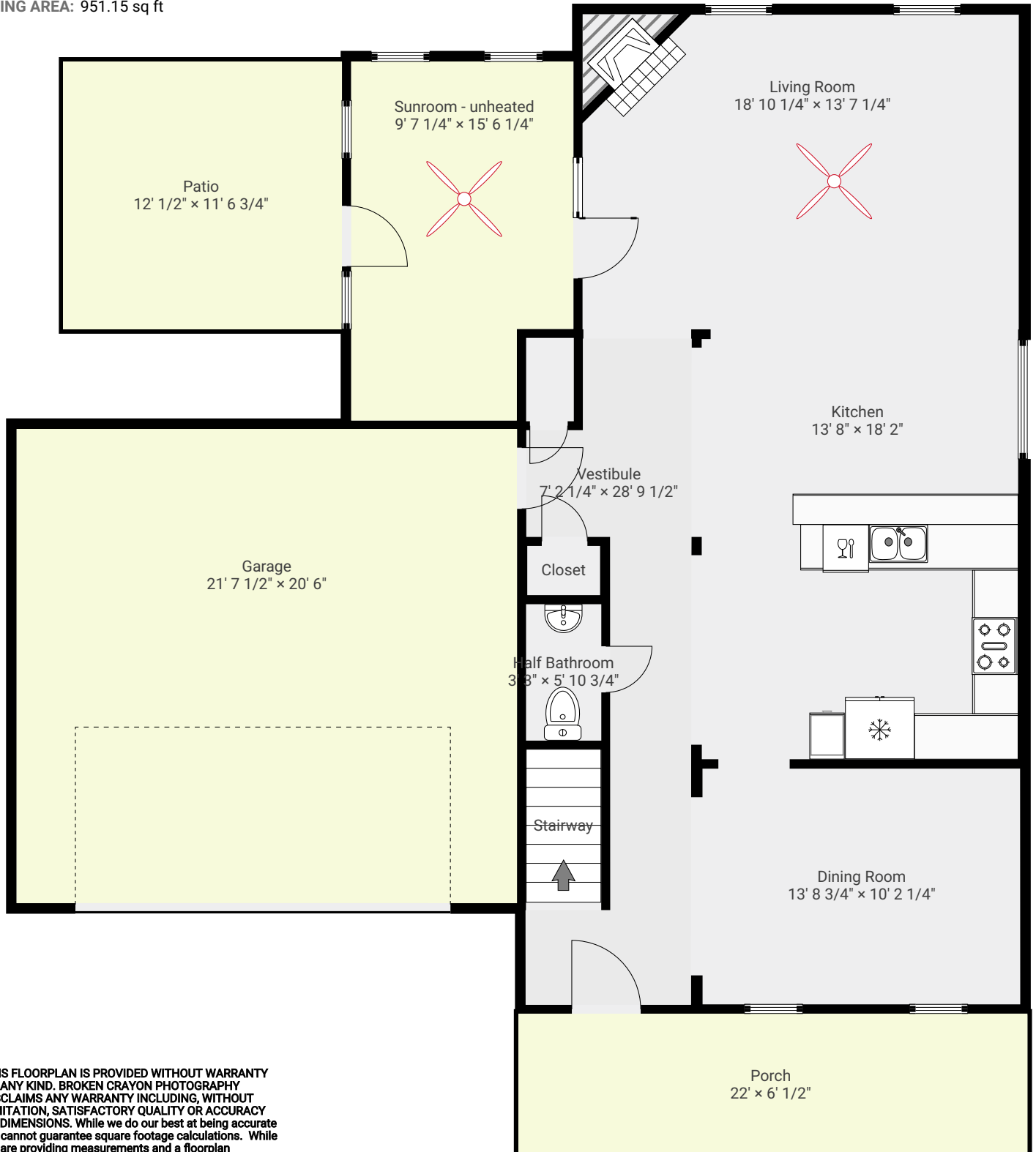

THIS FLOORPLAN IS PROVIDED WITHOUT WARRANTY OF ANY KIND. BROKEN CRAYON PHOTOGRAPHY DISCLAIMS ANY WARRANTY INCLUDING, WITHOUT LIMITATION, SATISFACTORY QUALITY OR ACCURACY OF DIMENSIONS. While we do our best at being accurate we cannot guarantee square footage calculations. While we are providing measurements and a floorplan ultimately the real estate agent is responsible to make sure it's accurate. If you see a discrepancy let us know immediately!

LIVING AREA: 2698.58 sq ft • FLOORS: 3

▼ 2nd Floor

LIVING AREA: 1185.52 sq ft

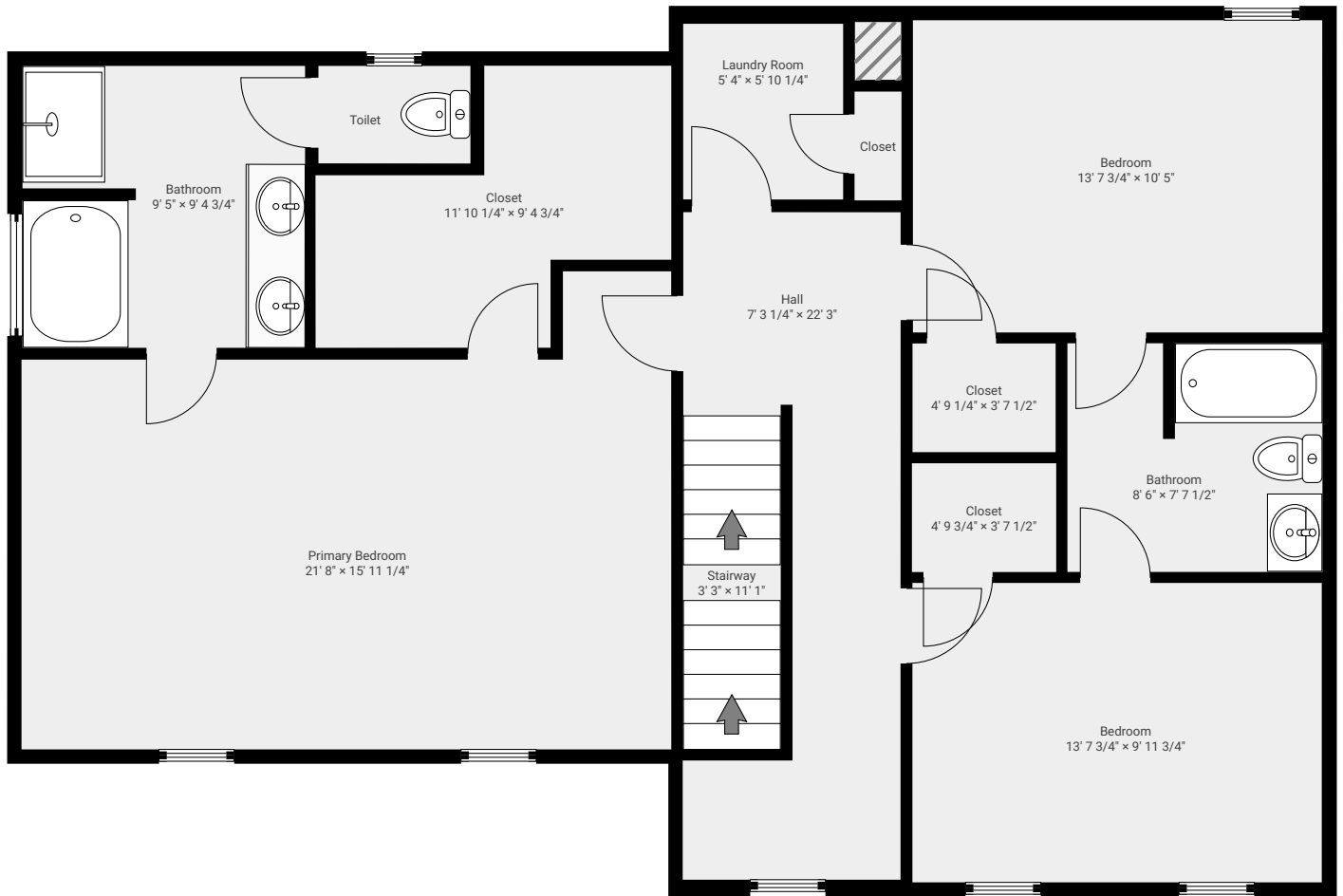

LIVING AREA: 2698.58 sq ft • FLOORS: 3

▼ 3rd Floor

LIVING AREA: 561.91 sq ft

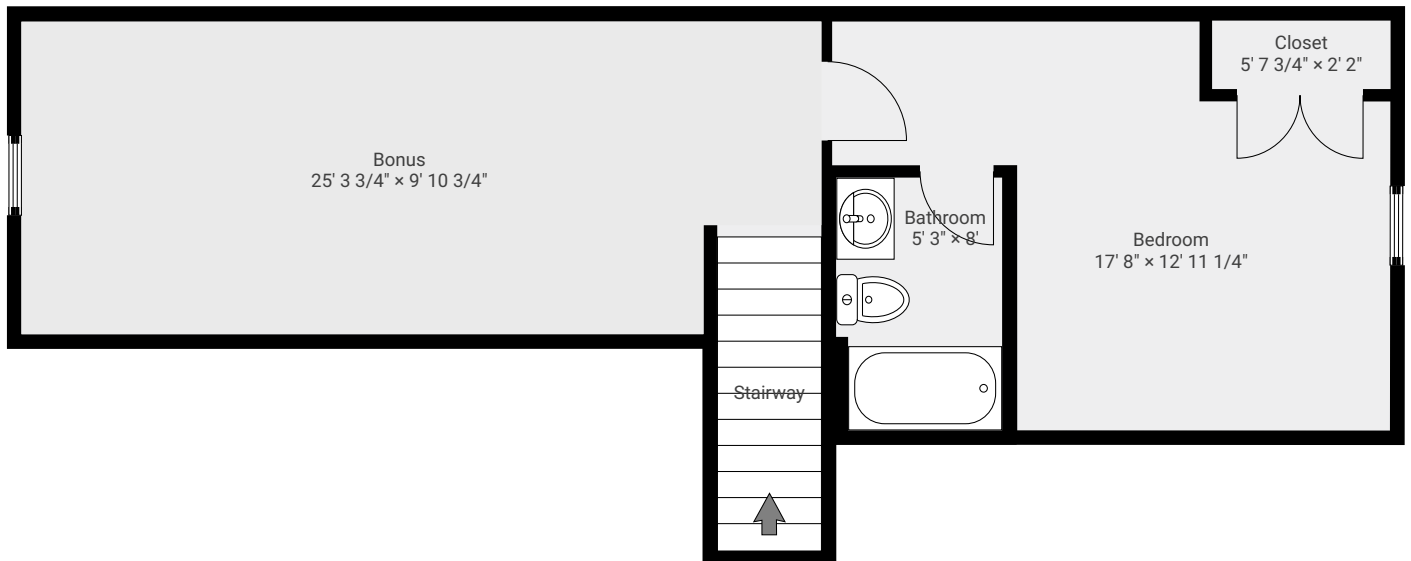

TOTAL AREA: 3571.70 sq ft • LIVING AREA: 2698.58 sq ft • FLOORS: 3

▼ **Dining Room**
Ground Floor

WIDTH: 13' 8 3/4" • LENGTH: 10' 2 1/4"
AREA: 139.87 sq ft • PERIMETER: 47' 10"

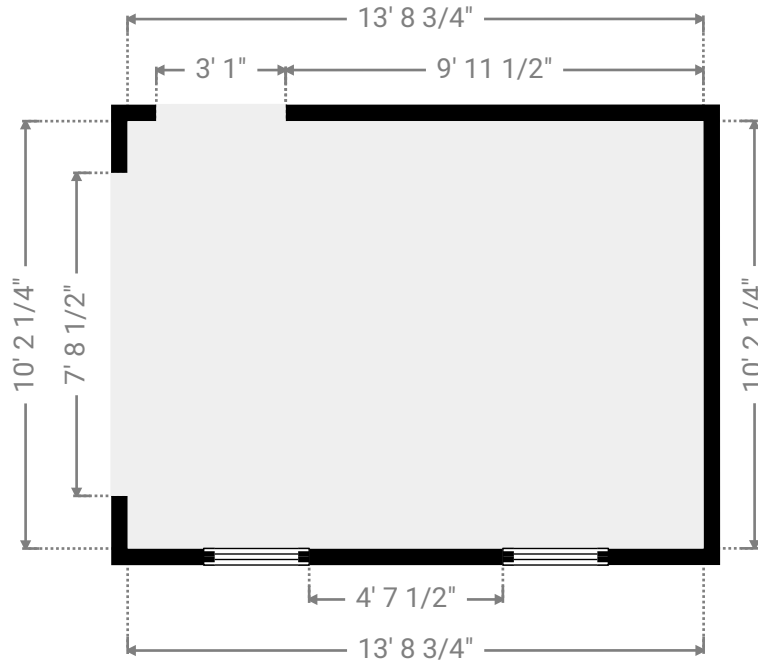
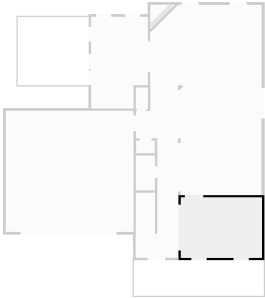

▼ **Furnace Room**
Ground Floor

WIDTH: 2' 3/4" • LENGTH: 3' 7 1/4"
AREA: 7.43 sq ft • PERIMETER: 11' 4"

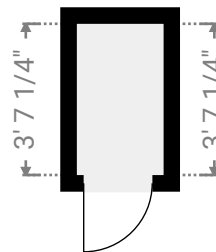
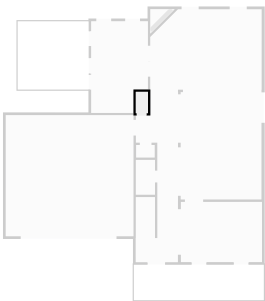

TOTAL AREA: 3571.70 sq ft • LIVING AREA: 2698.58 sq ft • FLOORS: 3

▼ **Garage**
Ground Floor

WIDTH: 21' 7 1/2" • LENGTH: 20' 6"
AREA: 443.26 sq ft • PERIMETER: 84' 3"

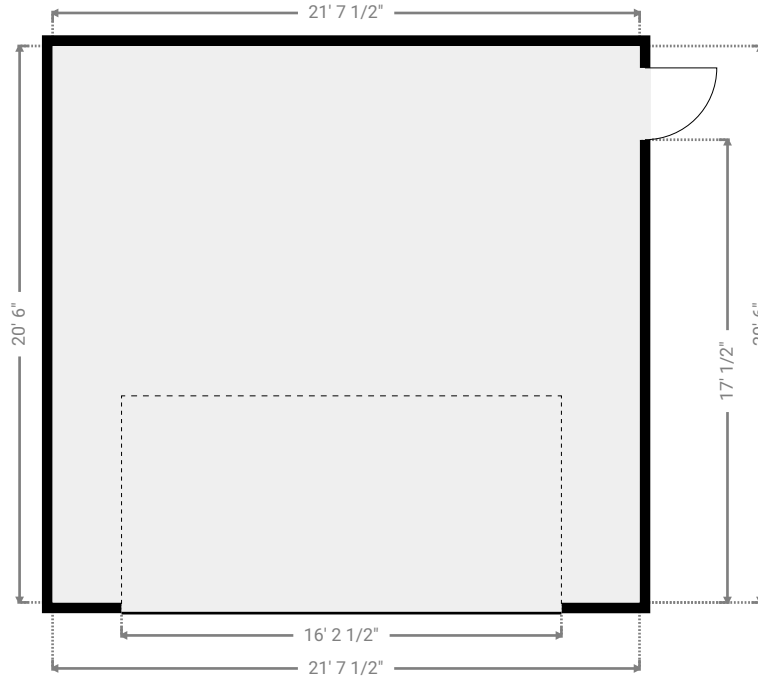
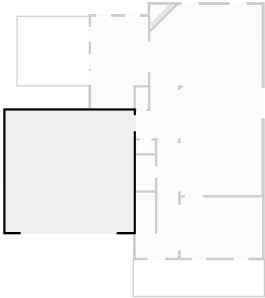

▼ **Half Bathroom**
Ground Floor

WIDTH: 3' 3" • LENGTH: 5' 10 3/4"
AREA: 19.16 sq ft • PERIMETER: 18' 3 1/2"

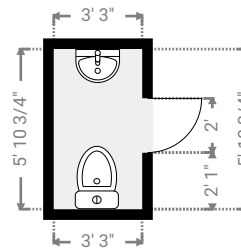
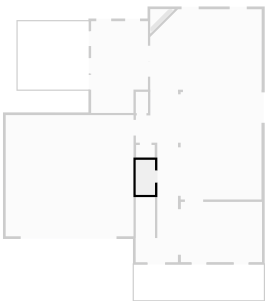

TOTAL AREA: 3571.70 sq ft • LIVING AREA: 2698.58 sq ft • FLOORS: 3

▼ **Kitchen**
Ground Floor

WIDTH: 13' 8" • LENGTH: 18' 2"
AREA: 248.37 sq ft • PERIMETER: 63' 8 1/4"

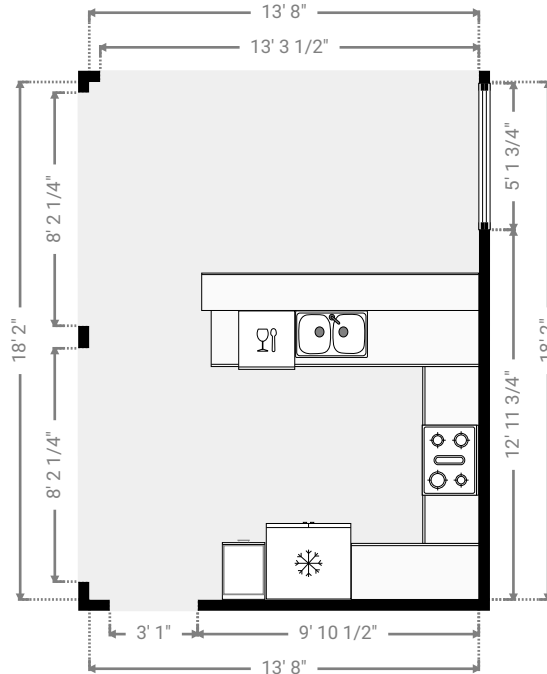

▼ **Living Room**
Ground Floor

WIDTH: 18' 10 1/4" • LENGTH: 13' 7 1/4"
AREA: 245.46 sq ft • PERIMETER: 62' 2"

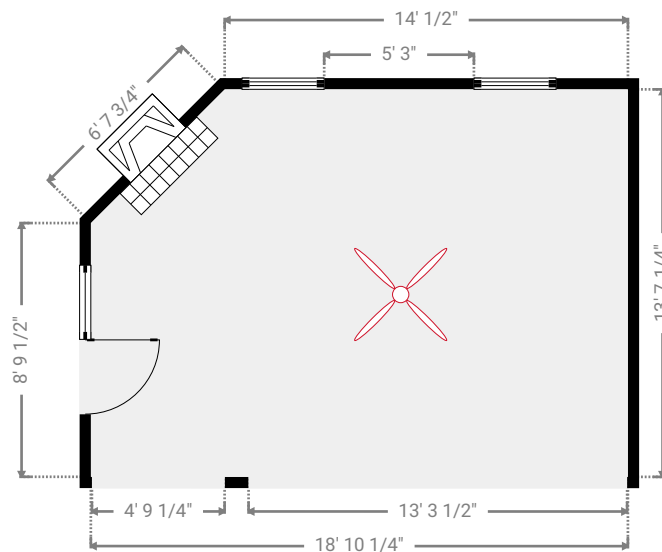
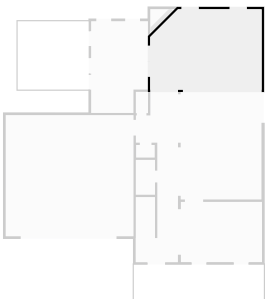

TOTAL AREA: 3571.70 sq ft • LIVING AREA: 2698.58 sq ft • FLOORS: 3

▼ **Porch**
Ground Floor

WIDTH: 22' • LENGTH: 6' 1/2"
AREA: 132.93 sq ft • PERIMETER: 56' 1"

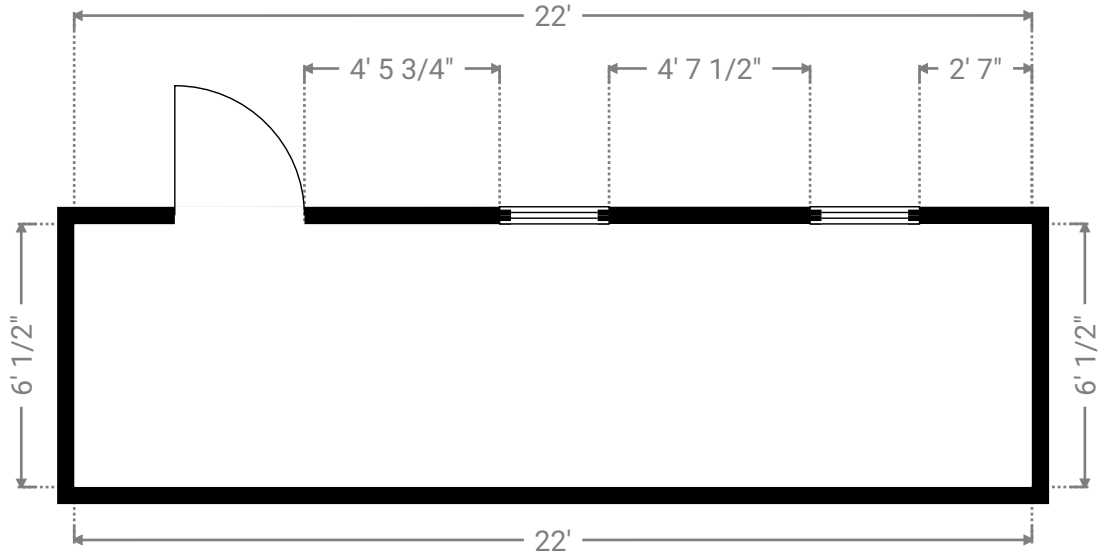

▼ **Stairway**
Ground Floor

WIDTH: 3' 3" • LENGTH: 6' 6 3/4"
AREA: 21.37 sq ft • PERIMETER: 19' 7 3/4"

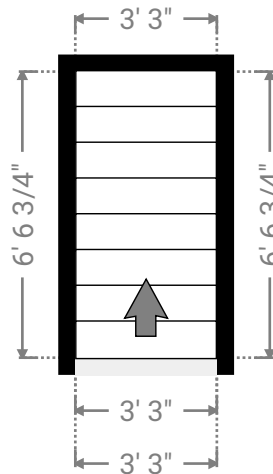
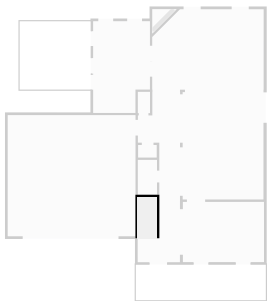

TOTAL AREA: 3571.70 sq ft • LIVING AREA: 2698.58 sq ft • FLOORS: 3

▼ **Sunroom - unheated**
Ground Floor

WIDTH: 9' 7 1/4" • LENGTH: 15' 6 1/4"
AREA: 139.37 sq ft • PERIMETER: 50' 3"

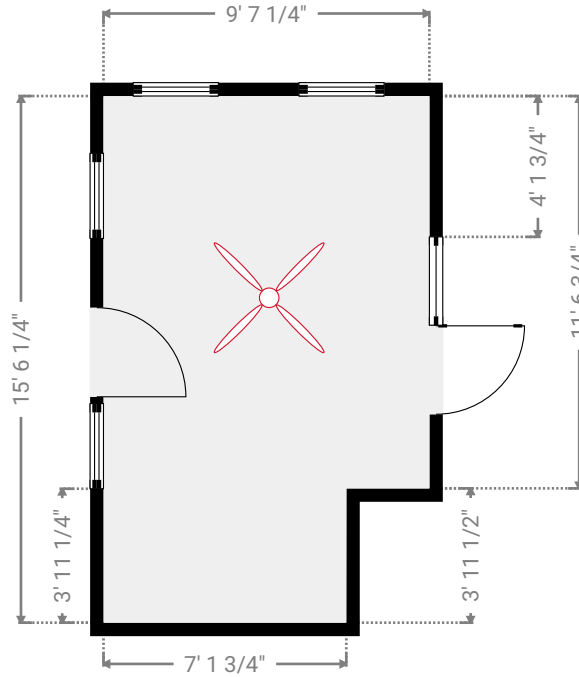
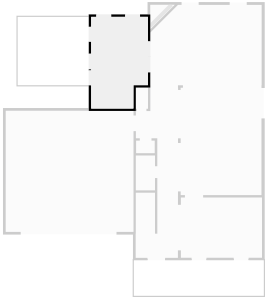

▼ **Patio**
Ground Floor

WIDTH: 12' 1/2" • LENGTH: 11' 6 3/4"
AREA: 139.24 sq ft • PERIMETER: 47' 2 1/2"

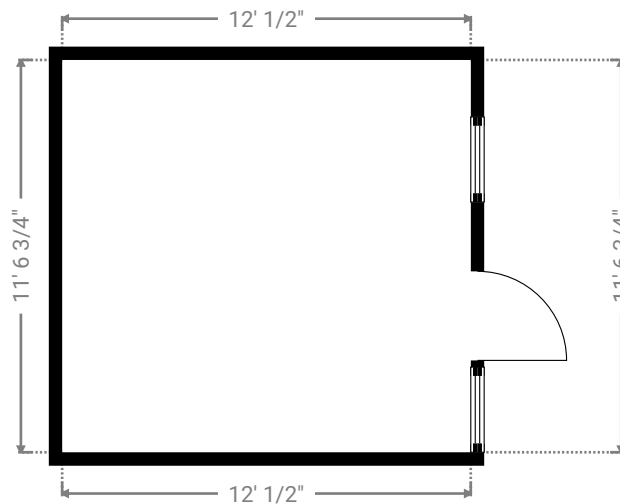
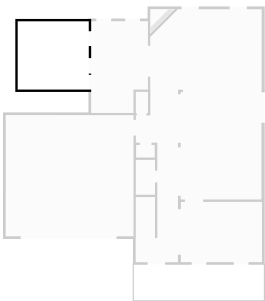

TOTAL AREA: 3571.70 sq ft • LIVING AREA: 2698.58 sq ft • FLOORS: 3

▼ **Vestibule**
Ground Floor

WIDTH: 7' 2 1/4" • LENGTH: 28' 9 1/2"
AREA: 137.05 sq ft • PERIMETER: 79' 2"

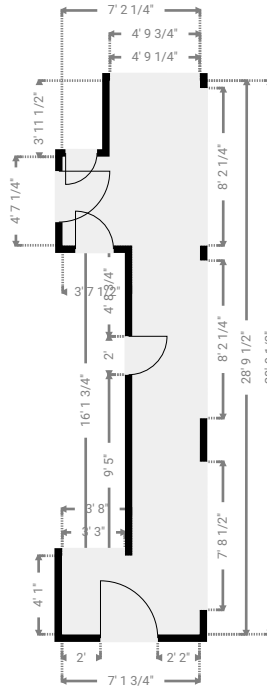
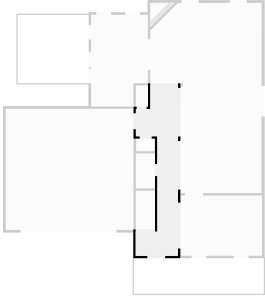

▼ **Closet**
Ground Floor

WIDTH: 3' 1 3/4" • LENGTH: 2' 1 1/2"
AREA: 6.69 sq ft • PERIMETER: 10' 6 1/2"

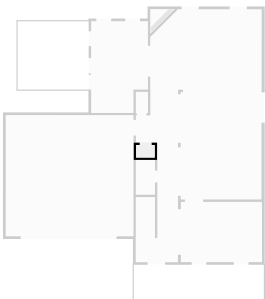

TOTAL AREA: 3571.70 sq ft • LIVING AREA: 2698.58 sq ft • FLOORS: 3

▼ Bathroom
2nd Floor

WIDTH: 8' 6" • LENGTH: 7' 7 1/2"
AREA: 63.54 sq ft • PERIMETER: 38' 7 3/4"

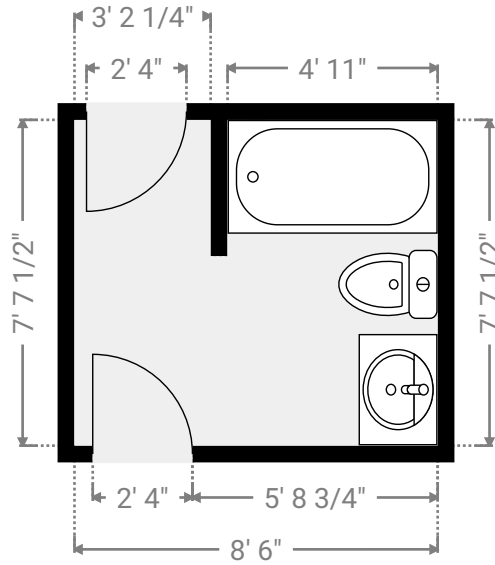
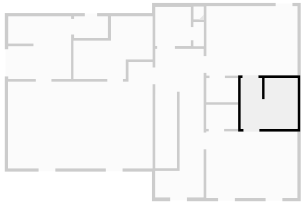

▼ Bathroom
2nd Floor

WIDTH: 9' 5" • LENGTH: 9' 4 3/4"
AREA: 86.98 sq ft • PERIMETER: 45' 2 1/4"

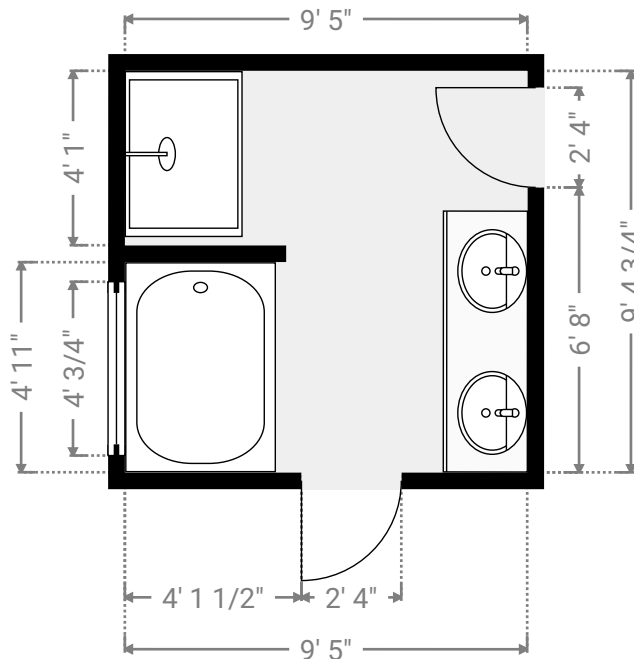
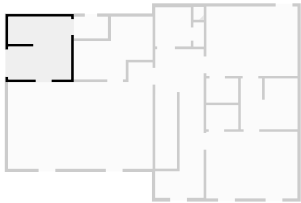

TOTAL AREA: 3571.70 sq ft • LIVING AREA: 2698.58 sq ft • FLOORS: 3

▼ **Bedroom**
2nd Floor

WIDTH: 13' 7 3/4" • LENGTH: 10' 5"
AREA: 142.01 sq ft • PERIMETER: 48' 1 1/4"

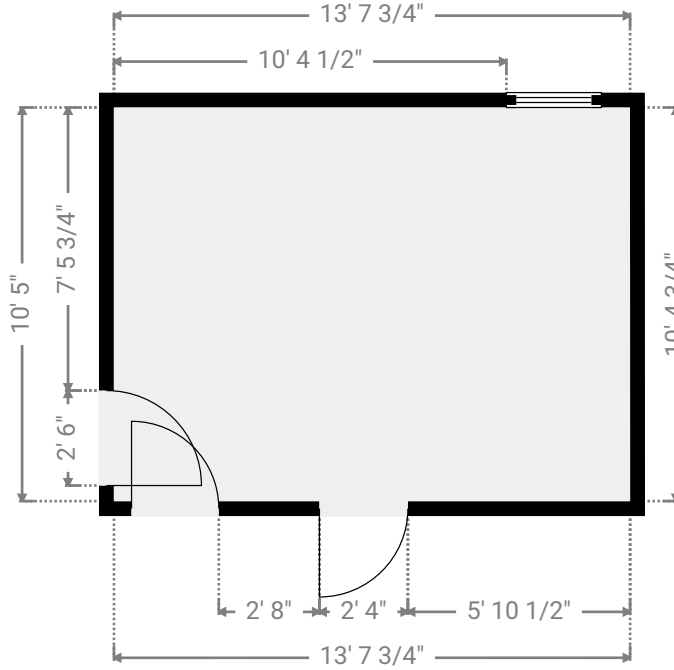
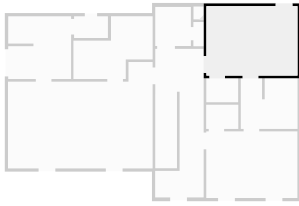

▼ **Closet**
2nd Floor

WIDTH: 4' 9 1/4" • LENGTH: 3' 7 1/2"
AREA: 17.29 sq ft • PERIMETER: 16' 9 1/2"

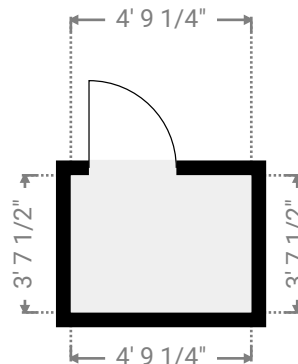
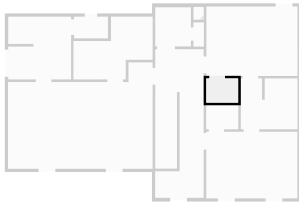

TOTAL AREA: 3571.70 sq ft • LIVING AREA: 2698.58 sq ft • FLOORS: 3

▼ **Bedroom**
2nd Floor

WIDTH: 13' 7 3/4" • LENGTH: 9' 11 3/4"
AREA: 136.17 sq ft • PERIMETER: 47' 3"

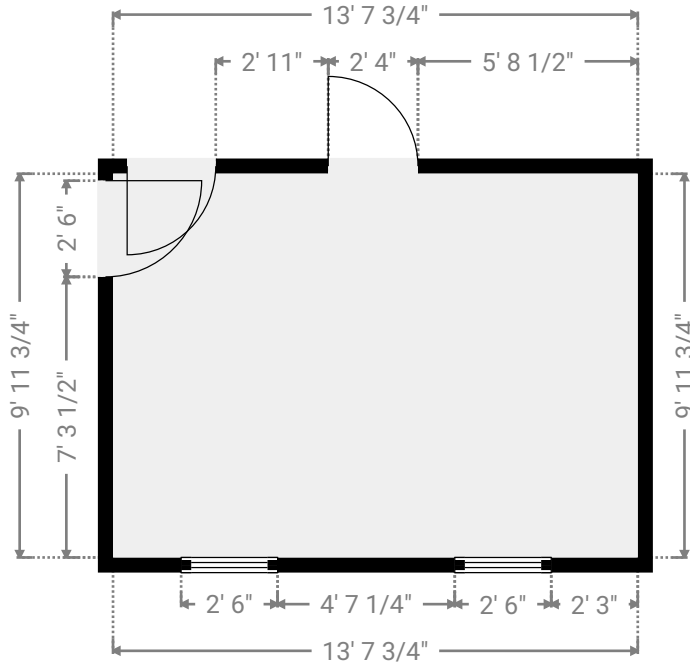
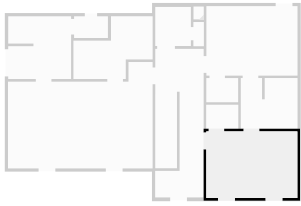

▼ **Closet**
2nd Floor

WIDTH: 4' 9 3/4" • LENGTH: 3' 7 1/2"
AREA: 17.44 sq ft • PERIMETER: 16' 10 1/2"

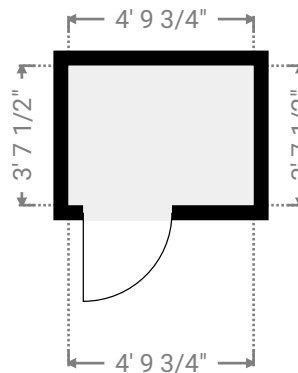
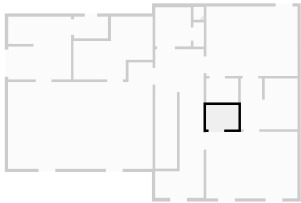

TOTAL AREA: 3571.70 sq ft • LIVING AREA: 2698.58 sq ft • FLOORS: 3

▼ **Hall**
2nd Floor

WIDTH: 7' 3 1/4" • LENGTH: 22' 3"
AREA: 118.14 sq ft • PERIMETER: 66' 3 3/4"

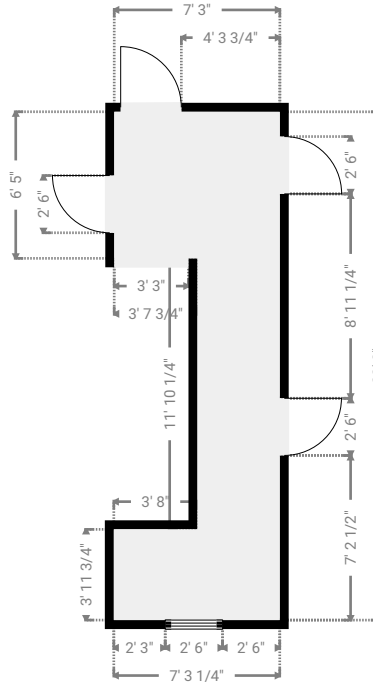
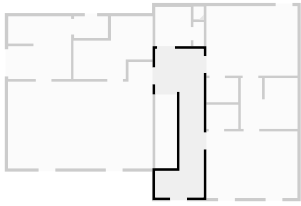

▼ **Laundry Room**
2nd Floor

WIDTH: 5' 4" • LENGTH: 5' 10 1/4"
AREA: 31.22 sq ft • PERIMETER: 22' 4 1/2"

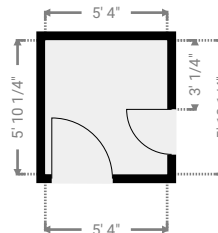
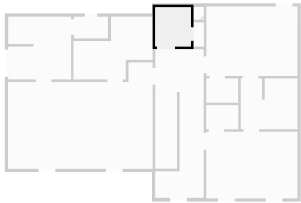

TOTAL AREA: 3571.70 sq ft • LIVING AREA: 2698.58 sq ft • FLOORS: 3

▼ **Closet**
2nd Floor

WIDTH: 1' 6 3/4" • LENGTH: 3' 7 1/2"
AREA: 5.66 sq ft • PERIMETER: 10' 4 1/2"

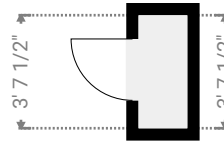
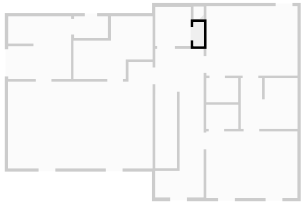

▼ **Primary Bedroom**
2nd Floor

WIDTH: 21' 8" • LENGTH: 15' 11 1/4"
AREA: 292.08 sq ft • PERIMETER: 75' 2 1/4"

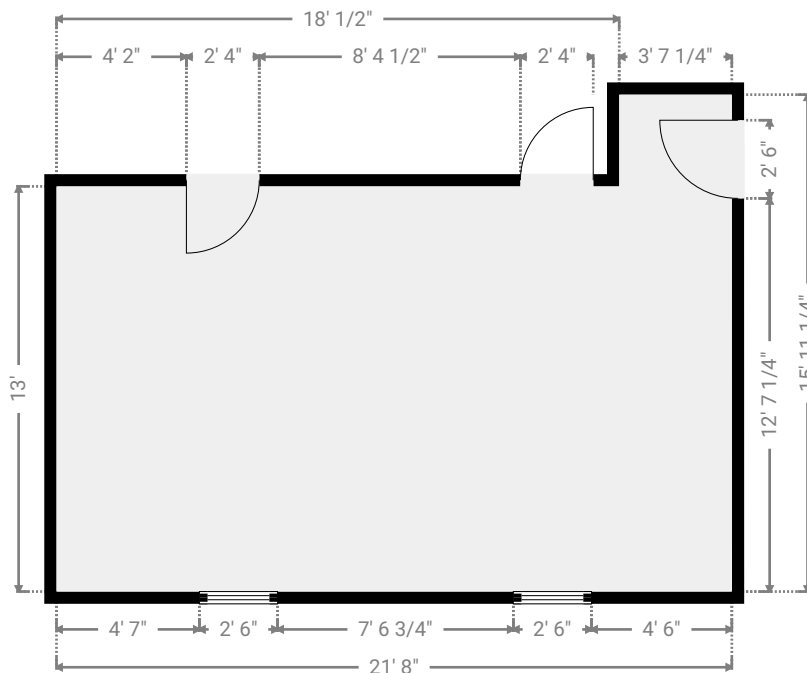
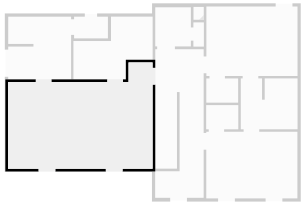

TOTAL AREA: 3571.70 sq ft • LIVING AREA: 2698.58 sq ft • FLOORS: 3

▼ **Closet**
2nd Floor

WIDTH: 11' 10 1/4" • LENGTH: 9' 4 3/4"
AREA: 79.13 sq ft • PERIMETER: 42' 6 1/4"

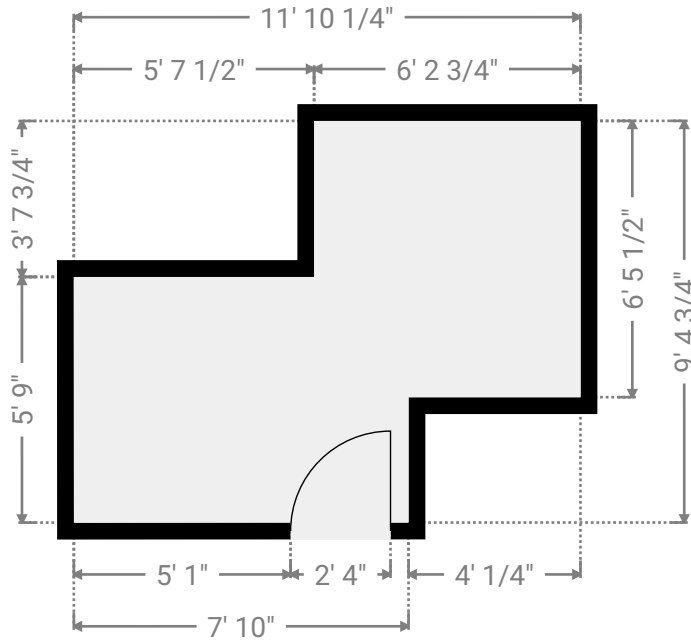
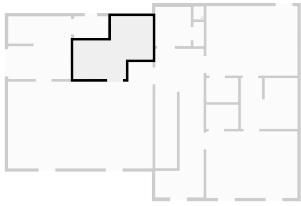

▼ **Stairway**
2nd Floor

WIDTH: 3' 3" • LENGTH: 11' 1"
AREA: 36.05 sq ft • PERIMETER: 28' 8"

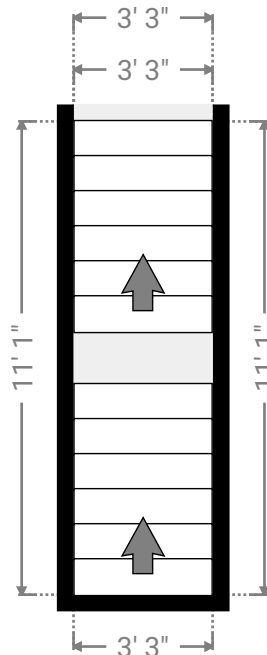
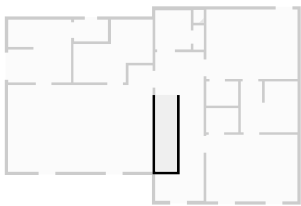

TOTAL AREA: 3571.70 sq ft • LIVING AREA: 2698.58 sq ft • FLOORS: 3

▼ Toilet
2nd Floor

WIDTH: 5' 3/4" • LENGTH: 3' 3"
AREA: 16.46 sq ft • PERIMETER: 16' 7 1/2"

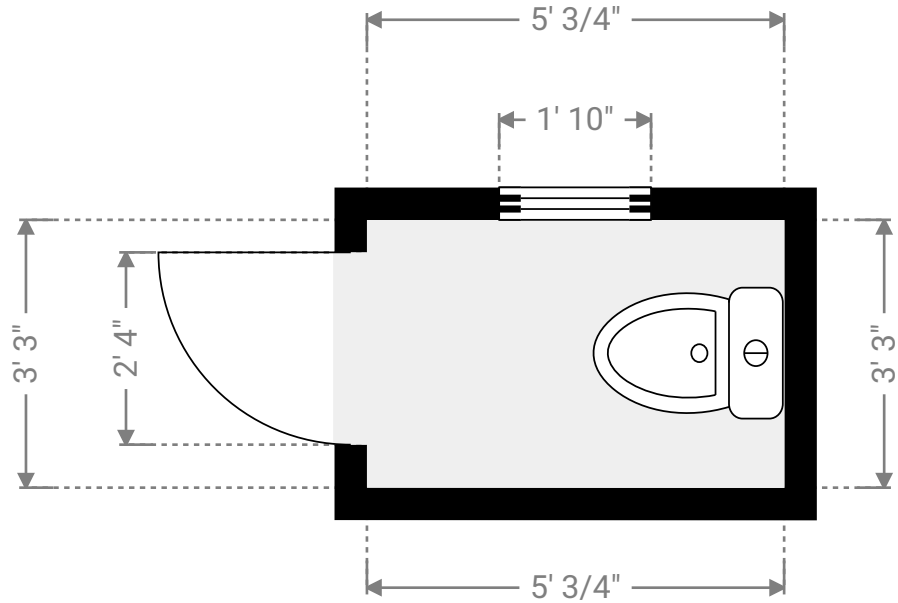
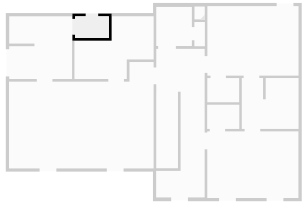

TOTAL AREA: 3571.70 sq ft • LIVING AREA: 2698.58 sq ft • FLOORS: 3

▼ **Bathroom**
3rd Floor

WIDTH: 5' 3" • LENGTH: 8'
AREA: 40.90 sq ft • PERIMETER: 26' 6"

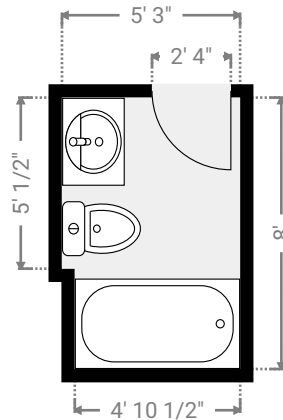
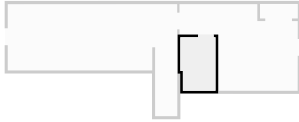

▼ **Bedroom**
3rd Floor

WIDTH: 17' 8" • LENGTH: 12' 11 1/4"
AREA: 164.02 sq ft • PERIMETER: 61' 2 1/4"

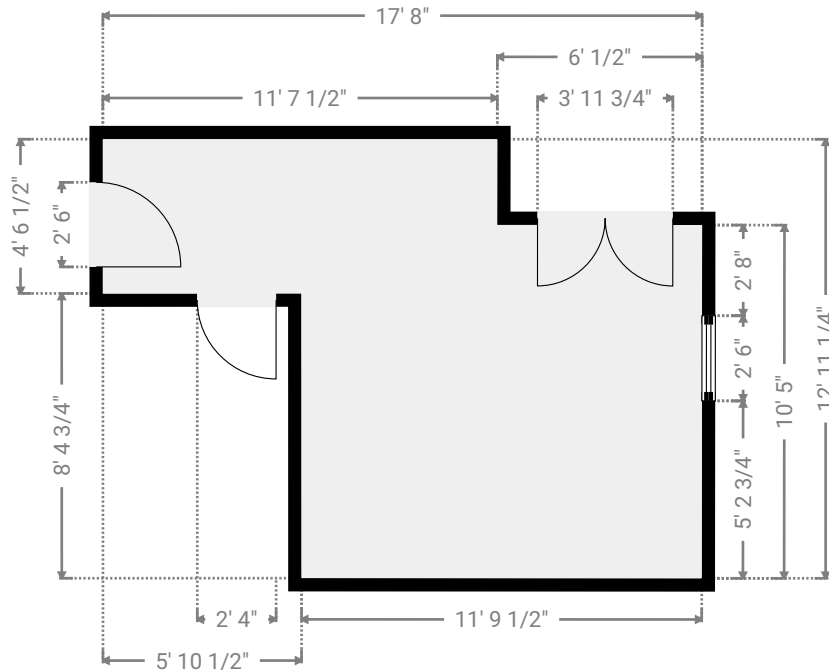
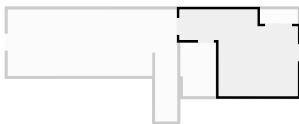

TOTAL AREA: 3571.70 sq ft • LIVING AREA: 2698.58 sq ft • FLOORS: 3

▼ **Closet**
3rd Floor

WIDTH: 5' 7 3/4" • LENGTH: 2' 2"
AREA: 12.23 sq ft • PERIMETER: 15' 7 1/2"

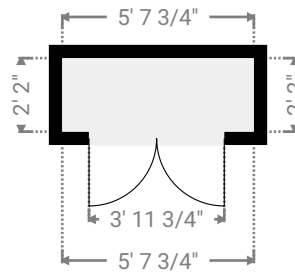
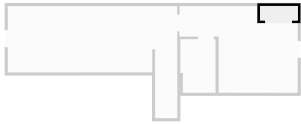

▼ **Bonus**
3rd Floor

WIDTH: 25' 3 3/4" • LENGTH: 9' 10 3/4"
AREA: 237.63 sq ft • PERIMETER: 70' 5"

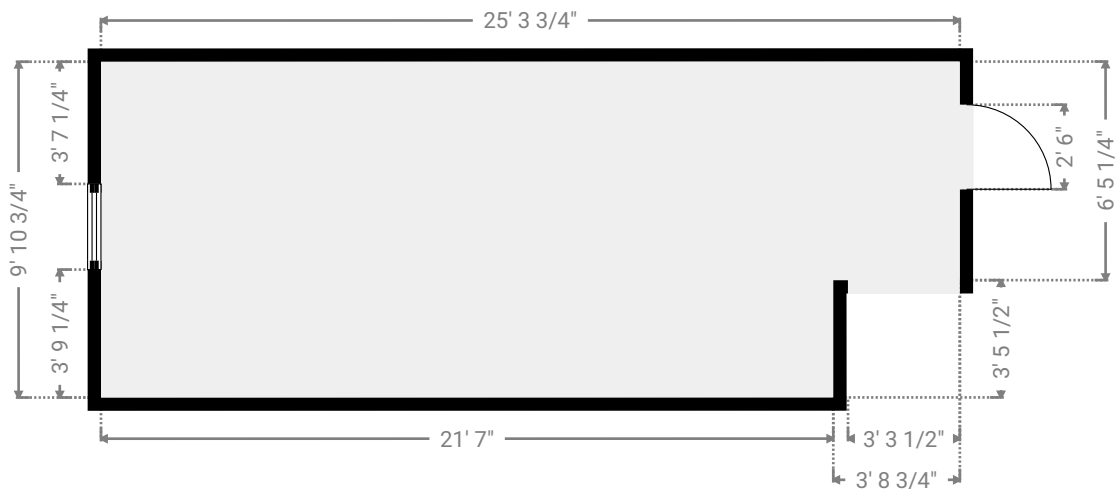
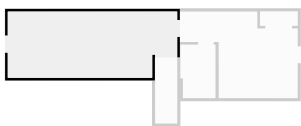

TOTAL AREA: 3571.70 sq ft • LIVING AREA: 2698.58 sq ft • FLOORS: 3

▼ **Stairway**
3rd Floor

WIDTH: 3' 3 3/4" • LENGTH: 9' 10 3/4"
AREA: 32.79 sq ft • PERIMETER: 26' 5"

